

INSTALLATION CERTIFICATE

The undersigned qualified installer attests to have personally fitted the here described vehicle security system following the manufacturer instructions.

By :

Sold on :

Type of product : 931T

Vehicle :

Gemini permanently fitted aftermarket equipment must be installed by qualified and authorised installers.

Thattham recommends to its insurer members that the installations of certified products within the aftermarket are registered with an independent installation registration system which can be accessed by insurance companies.

Thattham administers the Thattham Recognised Installer scheme, on behalf of the British motor insurance industry, providing independent registration of installations to vehicle owners.

Details of the Thattham Recognised Installer scheme can be found at www.thatcham.org.

To ensure consumers insurance cover is not adversely affected it is highly recommended that all installations are carried out by Thattham recognised installers and that all installs are registered providing the vehicle owner with a Thattham recognition of installation for presentation to insurers.

Thattham recommends to its insurer members that the installations of certified products within the aftermarket are registered with an independent installation registration system which can be accessed by insurance companies.

If seeking insurer recognition for the fitment of this product it is likely that the installation will have to be carried out by a Thattham recognised installer.

A full list of Thattham recognised installers is available at www.thatcham.org.

GEMINI Technologies S.p.A.

Via Luigi Galvani 12 - 21020 Bodio Lomnago (VA) - Italia

Tel. +39 0332 943211 - Fax +39 0332 948080

Web site: www.gemini-alarm.com



931T

INSTALLATION AND USE MANUAL



Made in Italy

AC 2800 Rev. 00 - 02/11

1.0 - PRELIMINARY ADVICE	PAGE 03
USER MANUAL	
2.0 - OPERATING DESCRIPTION	PAGE 03
2.1 - Complete system arming.....	PAGE 03
2.2 - System arming with sensor and comfort control exclusion.....	PAGE 03
2.3 - Passive arming.....	PAGE 03
2.4 - Arming inhibit time.....	PAGE 03
2.5 - System armed.....	PAGE 03
2.6 - Alarm, inhibit time between alarms and alarm cycles.....	PAGE 04
2.7 - System disarming.....	PAGE 04
2.8 - Emergency disarming by electronic key.....	PAGE 04
2.9 - Alarm memory.....	PAGE 04
3.0 - WARRANTY CONDITIONS	PAGE 04
4.0 - WASTE ELECTRICAL AND ELECTRONIC EQUIPMENT (WEEE) DIRECTIVE	PAGE 05
5.0 - TECHNICAL SPECIFICATIONS	PAGE 05
INSTALLER MANUAL	
6.0 - CONNECTORS TABLES	PAGE 06
6.1 - 20-way connector.....	PAGE 06
6.2 - 8-way connector.....	PAGE 06
7.0 - COMPLETE ELECTRIC DIAGRAM	PAGE 07
8.0 - WIRING DIAGRAMS FOR TURN INDICATORS	PAGE 08
8.1 - Standard connections.....	PAGE 08
8.2 - Connections for vehicles with separate lines.....	PAGE 08
8.0 - Connection to hazard push-button.....	PAGE 08
9.0 - SELECTION OF CENTRAL DOOR LOCKING CONNECTIONS TO ARM/DISARM THE SYSTEM	PAGE 09
9.1 - Connections and management by CAN-BUS line.....	PAGE 09
9.2 - Connections to door lock motor unit.....	PAGE 09
9.3 - Connections to turn indicators.....	PAGE 09
9.4 - "Mixed" connection option.....	PAGE 09
10.0 - VEHICLE CODE PROGRAMMING	PAGE 10
11.0 - SELF-LEARNING OF TURN INDICATORS FLASHES	PAGE 11
12.0 - SYSTEM PROGRAMMING	PAGE 12
12.1 - Optical signals.....	PAGE 12
12.2 - Acoustic signals.....	PAGE 12
12.3 - Passive arming.....	PAGE 12
12.4 - Enabling of siren (art. 7725T) output.....	PAGE 12
12.5 - Doors switch polarity selection.....	PAGE 12
12.6 - Negative output selection (during alarm) for horns or additional siren.....	PAGE 12
13.0 - SYSTEM PROGRAMMING EXAMPLE	PAGE 13
14.0 - ADDITION OF NEW DEVICES	PAGE 14
15.0 - DELETION OF PROGRAMMED DEVICES	PAGE 14
16.0 - ULTRASONIC VOLUMETRIC PROTECTION	PAGE 15
16.1 - Connections and positioning.....	PAGE 15
16.2 - Sensor adjustment.....	PAGE 15
17.0 - SYSTEM RESET	PAGE 15

1.0 - PRELIMINARY ADVICE

Dear Customer, the present manual illustrates the 931T alarm system. The following signs, intended for the installer or the user, indicate particular functions or connections as follows:



For the user.
This sign highlights useful information.



For the installer.
This sign indicates that the system will work according to the connections and the programming selected or it simply provides useful installation tips.

USER MANUAL

2.0 - OPERATING DESCRIPTION

2.1 - COMPLETE SYSTEM ARMING

Press the lock button on the original remote control of the vehicle; system arming is confirmed by one acoustic signal of the siren and one flash of the turn signals. The system has a 30" pre-arming "neutral time" (indicated by the LED turned on steady).

2.2 - SYSTEM ARMING WITH SENSOR AND COMFORT CONTROL EXCLUSION

The driver can arm the system and exclude the internal volumetric protection and comfort function. To activate this feature, the system should be disarmed and the ignition key turned "OFF"; proceed as follows.

- Insert the electronic key into the specific receptacle; the LED will flash quickly.
- Close vehicle doors and press the lock button on the original remote control.
- System activation is indicated by an acoustic signal with low tone and a flash of turn indicators.



Exclusion of sensors and comfort feature is bound to each single arming cycle.

2.3 - PASSIVE ARMING

When this function is programmed, the system passively arms about 60" after ignition is switched off and after the last door is opened and closed. System activation is indicated by the standard optic/acoustic signal.



If passive arming is activated, internal sensors and comfort output (automatic windows roll-up) are excluded. Opening a door 60" before the system is armed causes the procedure to interrupt; it is resumed once the door is closed.

2.4 - ARMING INHIBIT TIME

System inhibit arming time lasts approximately 30" and is indicated by the LED on; it is possible to exit the vehicle without triggering any alarm.

2.5 - SYSTEM ARMED

After the inhibit time the system is "armed" and ready to detect any theft attempt. When the system is fully armed, the LED flashes.

2.6 - ALARM, INHIBIT TIME BETWEEN ALARMS AND ALARM CYCLES

A theft attempt is indicated by acoustic/optic signals.

After the alarm is triggered, but before another alarm starts, the system goes into "neutral time for about 5".

An alarm event generates 10 alarm cycles of 30" each for each input and for each arming cycle.

2.7 - SYSTEM DISARMING

Press the unlock button on the original remote control of the vehicle.

System disarming is confirmed by two acoustic signals of the siren and two flashes of the turn indicators.

An alarm condition is signalled by five acoustic signals and five flashes from the turn indicators.

Paragraph 2.9 lists the various alarm causes and relative LED signals.

2.8 - EMERGENCY DISARMING BY ELECTRONIC KEY

This disarming mode is used for "EMERGENCY DISARMING" and "TOTAL DISARMING".

Touching the electronic key to its receptacle disarms and switches off the system which does not rearm when the remote control is used.



To restore normal operation, touch electronic key to its receptacle.
A quick chirp and a flash of the status LED confirm that the system is back to normal mode.

2.9 - ALARM MEMORY

Five flashes of the turn indicators and five acoustic signals upon disarming indicate a theft attempt.

The last cause of alarm can be identified by the LED memory.

Turn ignition key "ON"; the vehicle status LED blinks according to the last alarm detected.

Optical signals are repeated 3 times; to interrupt, turn ignition key "OFF".

The table below lists the various alarm causes and relative LED signals.

LED FLASHES	ALARM CAUSES	Nr. OF ALARM CYCLES
* * * ● * * *	Ignition attempt (+15/54)	10
* * * * ● * * * *	Doors opening	10
* * * * * ● * * * * *	Bonnet opening	10
* * * * * * * ● * * * * * *	Volumetric or external sensor	10
● LED OFF (2 seconds) * LED ON (1 second)		

3.0 - WARRANTY CONDITIONS

This product is guaranteed to be free from manufacturing defects for a period of 24 months from the installation date shown on this warranty, in compliance with the Directive 1999/44/CE.

Please fill-in entirely the guarantee certificate included in this booklet and do NOT REMOVE the guarantee label from the device.

The warranty will become void if labels are missing or torn, if the installation certificate is not fully compiled or if the enclosed sale document is missing.

The guarantee is valid exclusively at authorized Gemini Technologies S.p.A. Service Centers.

The manufacturer declines any responsibility for eventual malfunctions of the device or any damage to the vehicle electrical system due to improper installation, use or tampering.

This alarm system is solely intended to be a theft-deterrent device.

4.0 - WASTE ELECTRICAL AND ELECTRONIC EQUIPMENT (WEEE) DIRECTIVE

In the European Union, this label indicates that this product should not be disposed of with household waste. It should be deposited at an appropriate facility to enable recovery and recycling (directive 2002/95/CE, 2002/96/CE and 2003/108/CE).

For information on how to recycle this product responsibly in your Country, please visit the web-site:

Wwww.eur-lex.europa.eu



APPROPRIATE CONTAINER ONLY

5.0 - TECHNICAL SPECIFICATIONS

Power supply	12 Vdc
Current absorption @ 12Vdc with system armed and LED flashing	15 mA
Working range temperature	From -30°C to +70°C
Turn signals relay contact capacity	8 A at 20°C
Engine immobiliser relay contact capacity	8 A at 20°C
Alarm cycle duration	30 sec.
Maximum positive current output when armed (+A)	700 mA
Siren output current capacity	1 A

INSTALLER MANUAL

6.0 - CONNECTORS TABLES

6.1 - 20-WAY CONNECTOR

POSITION	WIRE FUNCTION	WIRE COLOUR
- 1 -	-----	-----
- 2 -	Signal for system arming/disarming	YELLOW-BLUE
- 3 -	Signal for system disarming/disarming	GREEN-BLUE
- 4 -	-----	-----
- 5 -	Doors push-button positive/negative input	GREEN-BROWN
- 6 -	Receptacle for electronic key input	GREEN
- 7 -	Receptacle for electronic key negative ground	BROWN
- 8 -	LED negative output	BLACK
- 9 -	LED positive output	RED
- 10 -	Positive under key	BLACK marked "G"
- 11 -	CAN BUS signal (CAN-H)	LIGHT BLUE-GREY
- 12 -	CAN BUS signal (CAN-L)	LIGHT BLUE
- 13 -	Positive output with system armed (+A)	PINK
- 14 -	External sensors output	GREEN-BLACK
- 15 -	Bonnet push-button negative input	GREEN
- 16 -	Pulse optic signalling	BLUE
- 17 -	Comfort negative output	WHITE-BLACK
- 18 -	Codified self-powered siren or vehicle claxson output	YELLOW-BLACK
- 19 -	Antenna	BLACK
- 20 -	Input for self-learning and system arming/disarming by turn indicators	WHITE-ORANGE



WHITE-ORANGE wire must ALWAYS be connected if system is to operate through the turn indicators.

6.2 - 8-WAY CONNECTOR

POSITION	WIRE FUNCTION	WIRE COLOUR
- 1 -	Ground	BLACK marked "M"
- 2 -	-----	-----
- 3 -	Positive	BLACK marked "R"
- 4 -	Turn signals positive output	ORANGE
- 5 -	-----	-----
- 6 -	-----	-----
- 7 -	-----	-----
- 8 -	Turn signals positive output	ORANGE

7.0 - COMPLETE ELECTRIC DIAGRAM

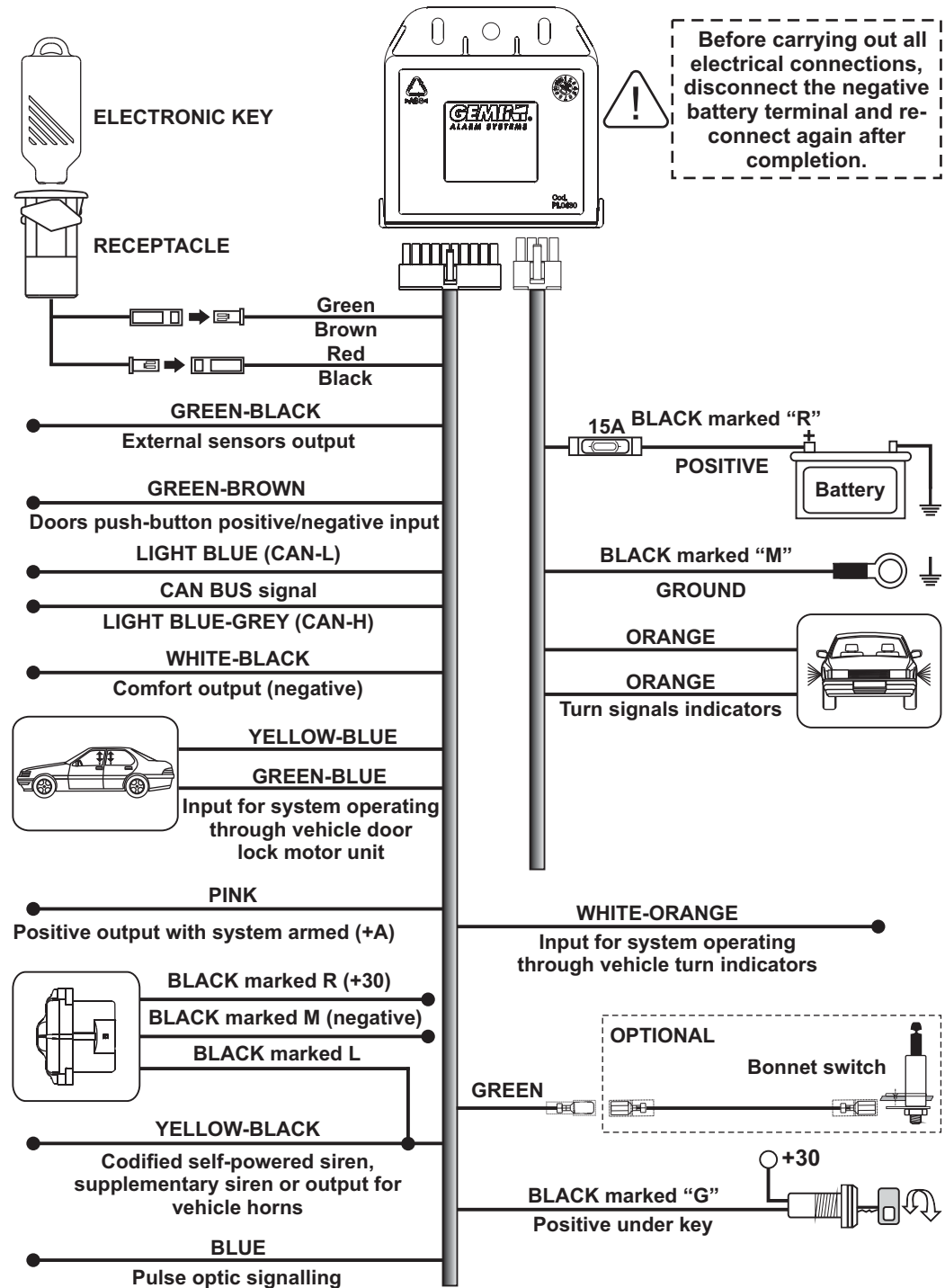

8.0 - WIRING DIAGRAMS FOR TURN INDICATORS

8.1 - STANDARD CONNECTIONS

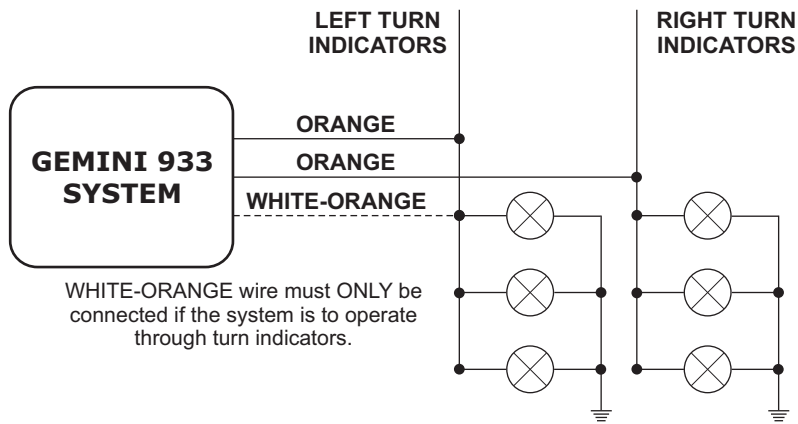

8.2 - CONNECTIONS FOR VEHICLES WITH SEPARATE LINES

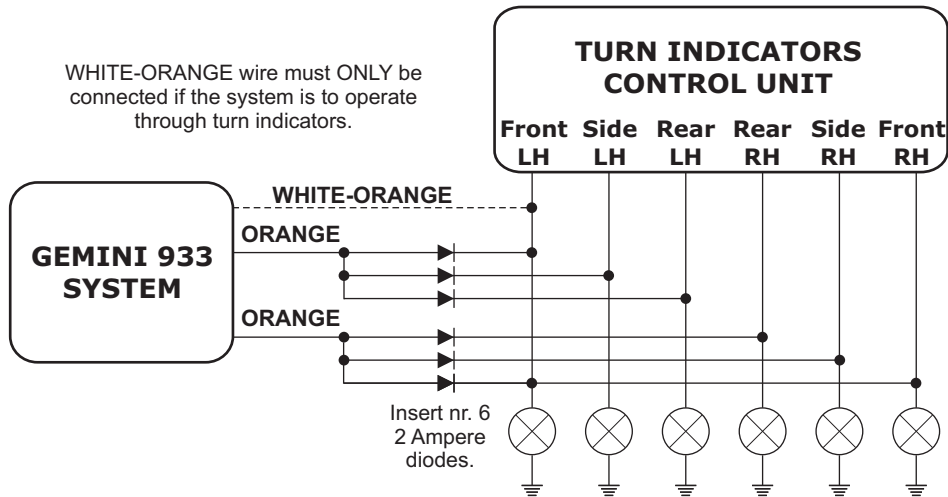

8.3 - CONNECTION TO HAZARD PUSH-BUTTON

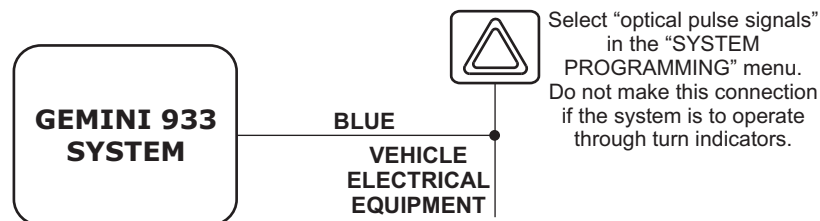

9.0 - SELECTION OF CENTRAL DOOR LOCKING CONNECTIONS TO ARM/DISARM THE SYSTEM

The 931T system can operate in various modes according to the vehicle on which it is installed and depending on the connections that can be made.

The CAN-BUS mode offers yet another operating solution.

It enables the system to be managed through the CAN-BUS line and operate in combination with the CAN signals, with the turn indicators flashes and/or the door lock motor unit.

The system automatically manages the different arming/disarming signals.

Consult the technical installation charts for the available connections for each vehicle. The various arming modes are listed below and the connections indicated in the following paragraphs.

- Arming through CAN-BUS line.
- Arming through door lock motor unit.
- Arming through self-learning of turn indicators flashes.
- Arming through turn indicators flashes and door lock motor unit.
- Arming through turn indicators flashes, door lock motor unit and CAN-BUS line.

9.1 - CONNECTIONS AND MANAGEMENT BY CAN-BUS LINE

System arming/disarming and alarm are managed through CAN-BUS line.

Therefore only connect the alarm system CAN BUS line to the vehicle CAN line wires (see available diagrams on the web-site www.gemini-alarm.com).

9.2 - CONNECTIONS TO DOOR LOCK MOTOR UNIT

System arming/disarming connections must be made to the vehicle door lock motor unit (polarity inversion).

9.3 - CONNECTIONS TO TURN INDICATORS

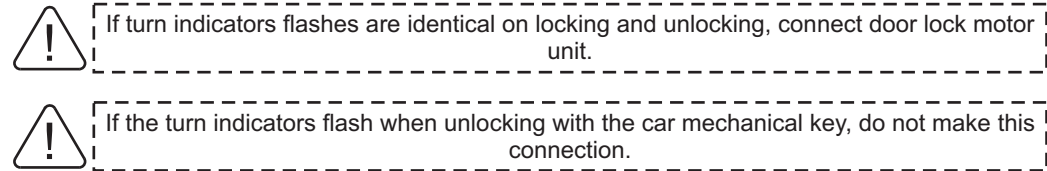

To arm/disarm the system, connect the WHITE-ORANGE wire to a wire of the turn indicators.

9.4 - "MIXED" CONNECTION OPTION

This type of connection allows the system to operate through the CAN BUS line with the turn indicators or the door lock motor unit or both.

The system automatically manages the different lock/unlock signals according to the programming and the connections made.

10.0 - VEHICLE CODE PROGRAMMING

If the system must work via CAN-BUS line, the alarm system needs to be configured according to the vehicle on which it is to be installed.

To help you understand the coding procedure, here below is an example illustrating the configuration procedure. In this case the code used is 1-0-3 which hypothetically corresponds to a "FIAT XXXXX".



A separate leaflet, included in the alarm packaging, lists all the available vehicles (codes are updated at packaging time).

Up-to-date information on supported vehicle models can be found at: www.gemini-alarm.com (private area).



The system has an indicator LED that signals any wrong vehicle code inserted. The code must be range between 100 and 235 otherwise the LED on the unit blinks repeatedly and the procedure is interrupted.

The previously inserted code remains stored.

The procedure is also invalidated if the LED blinks more than 10 times.

In this case there are no optical warnings, the procedure is simply be interrupted.

In either case, repeat the whole procedure.

Connect the 20-way wiring harness connector to the 20-way system connector.
Press and hold the button shown below until the LED lights up.

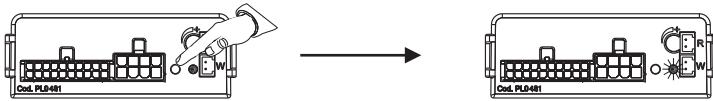

Release the button, the LED switches off.

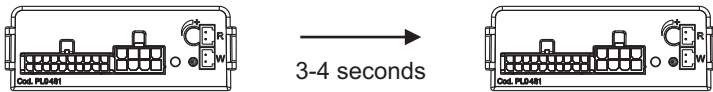

3-4 seconds

After 3/4 second pause the LED starts with the first sequence of flashes.
Push the button at first LED flashing, corresponding to value "1".



FIRST
FLASH

Push

After 4 second pause the LED starts with the second sequence of flashes.
Push the button at tenth LED flashing, corresponding to value "0".



TENTH
FLASH

Push

After 4 second pause the LED starts with the third sequence of flashes.
Push the button at third LED flashing, corresponding to value "3".



THIRD
FLASH

Push

When the last digit is entered, the alarm system "repeats" the entered code.



ONE FLASH AND A
SHORT PAUSE



TEN FLASHES AND
A SHORT PAUSE

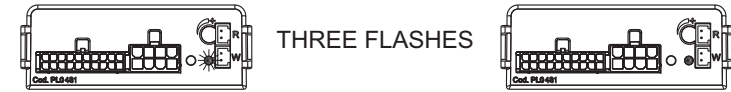

THREE FLASHES

Press the vehicle remote control lock/unlock buttons to make sure the alarm system works properly.

Eventually disconnect the 20-way connector and reconnect it after few seconds.

11.0 - SELF-LEARNING OF TURN INDICATORS FLASHES

In order to arm/disarm through the turn indicators, the system must learn the vehicle locking (arming)/unlocking (disarming) flashes.

Connect the WHITE-ORANGE wire to the turn indicators and then proceed as follows:

- Disconnect the 8-way wiring connector from the 8-way system connector.
- Turn ignition key "ON".
- Connect the 8-way wiring connector to the 8-way system connector; the LED turns on steady.
- Turn ignition key "OFF".
- Close all doors and press the lock button on the original remote control.
- When the turn indicators stop flashing, a high-pitched acoustic signal confirms the learning of the arming flashes.
- Press the unlock button on the original remote control.
- When the turn indicators stop flashing, 2 high-pitched audio signals confirm the learning of the disarming flashes.
- This completes the procedure.



To cancel the programming of the turn indicators reset the system (see chapter 17.0).

12.0 - SYSTEM PROGRAMMING

The table below applies to the system programmed in "standard configuration".
Every time you enter the programming procedure, the alarm resets to the default settings.

FUNCTION	STATUS	LED FLASHES
Exclusion of arming/disarming optic signalling	Disabled	*
Exclusion of arming/disarming acoustic signalling exclusion	Enabled	**
System passive arming	Disabled	***
Self-powered coded siren	Enabled	****
Doors input - positive	Disabled	*****
Negative pulse output during alarm cycle	Disabled	*****
For Gemini only, turn ignition key	Disabled	*****

A lack of power during electrical system maintenance, will not affect the programming.

The procedure must be carried out entirely.

Key rotation disables the selected function and moves to the next one until the programming procedure is completed.

Programmable functions are briefly described below and the next paragraph illustrates the programming instructions.

12.1 - OPTICAL SIGNALS

This function activates optical signals during system arming (1) and disarming (2).



If the vehicle already has optical locking/unlocking signals, the turn indicators alarm flashes should be deactivated.

12.2 - ACOUSTIC SIGNALS

This function activates acoustic signals during system arming (1) and disarming (2).

12.3 - PASSIVE ARMING

This function arms the system 60" after ignition is switched off and the last door is opened and closed. If a door is opened during this lapse of time, the procedure is interrupted and it resumes when the door is closed.

12.4 - ENABLING OF SIREN (ART. 7725T) OUTPUT

This function enables the codified communication from the alarm system to the self-powered coded siren (art. 7725T).

12.5 - DOORS SWITCH POLARITY SELECTION

This function modifies the alarm input signal (positive or negative) according to the signal generated by the doors switch.

12.6 - NEGATIVE OUTPUT SELECTION (DURING ALARM) FOR HORNS OR ADDITIONAL SIREN

If configured, this function can arm the output for the siren (continuous tone) or for the horn (intermittent tone).



Cannot be selected if the feature for the codified auxiliary siren (7725T) is activated.

13.0 - SYSTEM PROGRAMMING EXAMPLE

Here below is an example that illustrates the various steps to follow to modify the programmable functions.

As mentioned before, every key rotation disables a function, while the electronic key enables it.

When ignition is turned On or Off or the electronic key is touched to its receptacle, a high or low pitched signal sounds and the LED flashes according to table in chapter 12.0.

With alarm system disarmed, turn ignition key "ON" and touch electronic key to its receptacle.

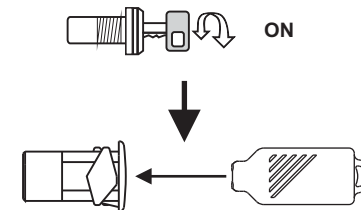

Two acoustic signals (a high and a low-pitched sound) and two flashes of the turn indicators indicate that the system is in the programming procedure.

Turn ignition "OFF" and then back "ON" to disable the function.

A low-pitched acoustic signal confirms the operation.
The LED flashes according to selected function (from 1 to 7).



OR

Insert electronic key once in its receptacle to activate the function.

A high-pitched acoustic signal confirms the operation.
The LED flashes according to selected function (from 1 to 7).



In both cases, system moves on to the next function.

Repeat steps above to enable or disable other functions.

When the last function is programmed (either with the electronic key or the ignition key), in addition to the confirmation tone, the system gives two low-pitched and one high-pitched acoustic signals and the turn indicators flash twice.

These last two signals indicate the end of the programming procedure.

14.0 - ADDITION OF NEW DEVICES

 To carry out the operation successfully, make sure the required electrical connections (bonnet push-button and positive under key) are complete.

To activate the procedure proceed as follows:

- With system disarmed, open the bonnet and leave it open.

 The following operations must be carried out within four seconds otherwise the procedure is invalidated.

- Turn ignition key “ON-OFF”-“ON-OFF”-“ON-OFF”-“ON”; at the fourth rotation, leave it “ON”.
- To confirm it has entered in the self-learning mode, the system gives two acoustic signals (one high and one low-pitched), the turn indicators flash once and the LED turns ON.

 Do not close the bonnet otherwise all previously programmed devices are erased as described in the next paragraph.

- Insert the electronic key into the receptacle; each time a device is learned a high-pitched signal sounds and the status LED turns OFF briefly.
- Repeat this procedure to store other devices.
- Turn ignition key “OFF”; the end of the procedure is indicated by a low-pitched signal sounds, the turn indicators flash once and the status LED turns OFF.

 Storing memory is for 55 devices; saving to memory the 56th. device has as a result the deletion of the first device installed in the location one of the alarm memory.

15.0 - DELETION OF PROGRAMMED DEVICES

 To carry out the operation successfully, make sure the required electrical connections (bonnet push-button and positive under key) have been made.

All device previously programmed in the memory can be erased; to clear memory proceed as follows:

- With system disarmed, open and keep opened the vehicle bonnet.

 The following operations must be carried out within four seconds otherwise the procedure is invalidated.

- Turn ignition key “ON-OFF”-“ON-OFF”-“ON-OFF”-“ON”; after the fourth rotation, leave it “ON”.
- To confirm it has entered in the delete mode, the system gives two acoustic signals (one high and one low-pitched), the turn indicators flash once and the LED turns ON.
- Close the bonnet and keep it closed (approx. 8 sec.) until the devices are completely deleted.

 If the bonnet is opened before 8 seconds, the devices will not be deleted.

- The status LED turns OFF when the devices have been deleted; turn ignition key “OFF”.
- The end of the procedure is indicated by one long low-pitched acoustic signal.

16.0 - ULTRASONIC VOLUMETRIC PROTECTION

16.1 - CONNECTIONS AND POSITIONING

Insert the WHITE connector in the “W” marked socket and the RED connector in the “R” marked socket (see figure below).

Install the transducers of the ultrasonic sensors on the top part of the windscreen internal pillars, away from the air vents and orient them towards the center of the rear window.

16.2 - SENSOR ADJUSTMENT

To check sensitivity level proceed as follows:

- With the alarm system disarmed, roll down the front window about 20 cm.
- Adjust trimmer at a medium setting.
- Close all doors, bonnet and boot and arm the system.
- During the system inhibit arming time introduce an object in the cabin through the window and move it around; the status LED will turn off to signal a presence.
- If sensinty lvlvel is too high or too low, readjust the trimmer and repeat the above procedure.

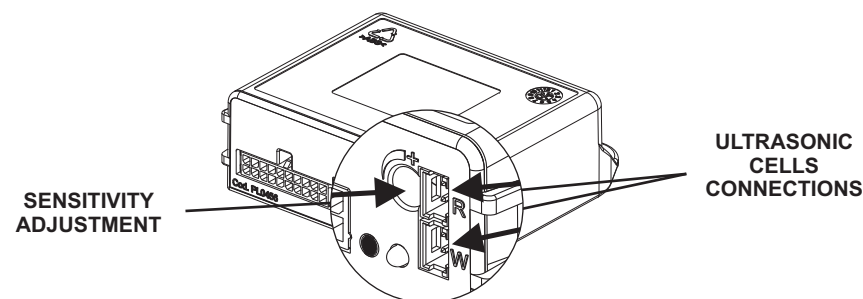

17.0 - SYSTEM RESET

 By activating the following procedure, the system returns to the Factory default setting. This procedure must therefore only be used in case of need, before programming the system or auto-learning the turn indicators flashes.

To reset the system proceed as follows:

- Switch-off system power supply.
- Short-circuit the RED and BLACK wires of the 2-way LED connector.
- Switch the system on; once the alarm system is powered, 4 acoustic signals will sound and the turn indicators will flash 4 times.
- Remove the previously created short-circuit; the status LED lights up steady.
- Turn ignition key “ON”; reset is confirmed by an aucoustic signal and the wailing of the siren for approx. 3 seconds.
- Turn ignition key “OFF”; the LED will turns off. There are no acoustic signals.