

## INSTALLATION CERTIFICATE

The undersigned qualified installer attests having personally fitted the alarm system on the vehicle specified below, following the manufacturer's instructions.

By :

Sold on :

Type of device :  973

Vehicle :

**GEMINI Technologies S.p.A.**  
Via Luigi Galvani 12 - 21020 Bodio Lomnago (VA) - Italia  
Tel. +39 0332 943211 - Fax +39 0332 948080  
Web site: [www.gemini-alarm.com](http://www.gemini-alarm.com)



# 973AR

## INSTALLATION AND USE MANUAL



Made in Italy

AC 2792/UK Rev. 01 - 11/10

<b>1.0 - PRELIMINARY ADVICE</b> .....	PAGE 03
<b>USER MANUAL</b>	
<b>2.0 - OPERATING DESCRIPTION</b> .....	PAGE 03
2.1 - Complete system arming.....	PAGE 03
2.2 - System arming with sensor exclusion.....	PAGE 03
2.3 - Arming inhibit time.....	PAGE 03
2.4 - System armed.....	PAGE 03
2.5 - Alarm, inhibit time between alarms and alarm cycles.....	PAGE 03
2.6 - System disarming.....	PAGE 04
2.7 - Alarm memory.....	PAGE 04
<b>3.0 - GARAGE FUNCTION</b> .....	PAGE 04
<b>4.0 - ANTI-HIJACK FEATURE</b> .....	PAGE 05
4.1 - Vehicle running: normal functioning.....	PAGE 05
4.2 - Vehicle running: aggression and hijack.....	PAGE 05
4.3 - Vehicle running: anti-hijack activation.....	PAGE 05
4.4 - Deactivation of anti-hijack feature.....	PAGE 05
<b>INSTALLER MANUAL</b>	
<b>5.0 - CONNECTOR TABLE</b> .....	PAGE 06
<b>6.0 - COMPLETE ELECTRIC DIAGRAM</b> .....	PAGE 07
<b>7.0 - SYSTEM PROGRAMMING</b> .....	PAGE 08
7.1 - Acoustic signalling.....	PAGE 08
7.2 - Current absorption sensor.....	PAGE 08
7.3 - Carjack.....	PAGE 08
7.4 - Optic signalling.....	PAGE 08
<b>8.0 - EXAMPLE OF SYSTEM PROGRAMMING</b> .....	PAGE 09
<b>9.0 - ADDING NEW DEVICES</b> .....	PAGE 10
<b>10.0 - DELETING PROGRAMMED DEVICES</b> .....	PAGE 11
<b>11.0 - ULTRASONIC VOLUMETRIC PROTECTION</b> .....	PAGE 12
11.1 - Connection and positioning.....	PAGE 12
11.2 - Sensor adjustment.....	PAGE 12
<b>12.0 - WASTE ELECTRICAL AND ELECTRONIC EQUIPMENT (WEE) DIRECTIVE</b> .....	PAGE 12
<b>13.0 - TAG CARD ACTIVATION AND BATTERY REPLACEMENT</b> .....	PAGE 13
<b>14.0 - WARRANTY CONDITIONS</b> .....	PAGE 14
<b>15.0 - TECHNICAL DATA</b> .....	PAGE 14

Dear customer,  
The following signs are intended to draw user and installer attention to particular functions or connections as follows:



**Indications useful for the user.**

This icon provides the user with indications for a diversified use of the system or it simply provides indications useful for the use.



**Indications useful for the installer.**

This icon indicates to the installer a diversified operating, according to the connection and the programming of the system or it simply provides indications useful for the installation.

**USER MANUAL**

**2.0 - OPERATING DESCRIPTION**

**2.1 - COMPLETE SYSTEM ARMING**

The system arms automatically 30" after turning off the engine (lack of ignition key contact) as long as no TAG transmission is detected.

System arming is confirmed by an acoustic signal and a flash of the turn indicators.

Opening a door 30" before the system is armed temporarily interrupts the procedure which will resume once the door is closed.

**2.2 - SYSTEM ARMING WITH SENSORS EXCLUSION**

This function allows the user to arm the system while excluding internal volumetric protection and positive with system armed (+A).

To activate this function, the system should be disarmed and the ignition key turned to the "OFF" position; proceed as follows.

- Close and keep driver door closed (make sure the courtesy light is off) and insert the electronic key into its receptacle.
- One brief flash of the turn indicators and of the LED indicate sensor exclusion.



Sensors exclusion is bound to each single arming cycle.

**2.3 - ARMING INHIBIT TIME**

Inhibit arming time lasts for approximately 16" and is indicated by the status LED turning ON steady; during this period you can exit the vehicle without triggering any alarm.

**2.4 - SYSTEM ARMED**

After inhibit time is over, the system is "armed" and ready to detect any theft attempt. When the system is fully armed, the LED flashes.

**2.5 - ALARM, INHIBIT TIME BETWEEN ALARMS AND ALARM CYCLES**

Before the alarm triggers an audio/visual signal there is a 16" pre-alarm neutral time.

The system indicates theft attempts by audio/visual signals (siren sounds and turn indicators flash).

After the alarm event, but before another alarm is triggered, there is a 5" neutral time.

The alarm generates 5 cycles of 30" each for each input and for each arming cycle.

## 2.6 - SYSTEM DISARMING

The armed system starts disarming when the driver walks up to the vehicle and TAG transmission is detected.

Disarming completes when the driver door is opened.

System disarming is confirmed by two beeps of the siren and two flashes of the turn indicators.

## 2.7 - ALARM MEMORY

If the turn indicators flash 5 times and the siren chirps 5 times upon disarming, the last cause of alarm can be identified by the LED memory.

Turn ignition key "ON" and look at the vehicle status LED; it will start blinking according to the last alarm condition (see table below).

The blinking will repeat 5 times, to interrupt turn vehicle ignition "OFF".

The various alarms are identified by the number of flashes as indicated in the table below.

LED FLASHES	ALARM CAUSE	N. OF ALARM CYCLES
* * ● * *	Starting attempt (+15/54)	5
* * * ● * * *	Door opening	5
* * * * ● * * * *	Bonnet opening	5
* * * * * ● * * * * *	Internal sensor	5
* * * * * * * * ● * * * * * * * *	Absorption sensor	5
* * * * * * * * * ● * * * * * * * * *	Wire tampering	5

● LED OFF (2 seconds)    \* LED ON (1 second)

## 3.0 - GARAGE FUNCTION



This garage feature "deactivates" the system and is useful when the vehicle is in a workshop for maintenance or repairs or if the TAG CARD is not working.

The garage feature can be activated with system armed or disarmed by inserting the electronic key in its receptacle while the driver door is opened.

The system is deactivated and the operation confirmed by an acoustic signal.

To reactivate the system simply introduce the electronic key in its receptacle.

The system activates and the operation confirmed by three acoustic signals.

To activate the garage feature during an alarm condition or during a hijack attempt (vehicle running) simply introduce the electronic key in its receptacle (door either opened or closed).



When the "garage feature" is ON, the status LED blinks twice followed by a 2 seconds pause.

## 4.0 - ANTI-HIJACK FEATURE



Arming the anti-hijack feature means that only TAG reception and identification is activated and not vehicle immobilization.

The 973AR alarm system has an anti-hijack feature for protection against aggression or vehicle theft. It operates by means of an automatic transmitter (TAG), which communicates with the 973AR module via a codified radio signal.

When ignition is turned OFF, the module arms and works as an alarm and the TAG as a remote control. When the vehicle is running and there is no TAG transmission, the alarm system activates the anti-hijack procedure, as described further on.



For security reasons, we recommend you keep your electronic key and TAG separate from your ignition key so that, if your vehicle is robbed, you have your electronic key and TAG with you.

This feature can be activated even if the vehicle is turned OFF; if it is turned ON and the system does not detect the TAG, the anti-hijack feature arms.

### 4.1 - VEHICLE RUNNING: NORMAL OPERATION

Under this condition, the system only detects TAG transmission and the LED does not blink.

### 4.2 - VEHICLE RUNNING: AGGRESSION AND HIJACKING

In case of car-jacking, the user should, as recommended, have his TAG with him.

If the door is opened and the driver walks away with the TAG, the module no longer detects radio contact and enters, after 90", in pre-arm mode.

### 4.3 - VEHICLE RUNNING: ANTI-HIJACK ACTIVATION

The turn indicators and the siren or the horn (if connected) will activate for 2 minutes.

20" after the audio/visual signals, the vehicle immobilizer will activate (20" ON/OFF up to a complete stop).

If the driver doesn't turn them off, the turn indicators will keep flashing for 3 hours while the siren or horn will sound for two minutes.

### 4.4 - DEACTIVATION OF ANTI-HIJACK FEATURE

To deactivate the anti-hijack feature all the driver has to do is walk up to his vehicle with the TAG.

The module, on intercepting the signal, will deactivate the anti-hijack feature and stop the optic and acoustic alarm signals.

Deactivation of the anti-carjack feature with electronic key will arm the "garage function" (see par. 3.0).

# INSTALLATION MANUAL

## 5.0 - CONNECTOR TABLE

POSITION	WIRE FUNCTION	WIRE COLOR
- 1 -	Bonnet push-button negative input	GREEN
- 1 -	External sensor negative input	GREEN-BLACK
- 2 -	Door push-button negative input	GREEN-BLACK
- 3 -	Positive under key	BLACK marked "G"
- 4 -	-----	-----
- 5 -	-----	-----
- 6 -	Ground	BLACK marked "M"
- 7 -	Negative output for siren or buzzer	YELLOW-BLACK
- 8 -	Positive output with system armed (+A)	PINK
- 9 -	Ground for LED and receptacle for electronic key	BLACK and BROWN
- 10 -	LED positive output	RED
- 11 -	Positive	BLACK marked "R"
- 12 -	Antenna	BLACK
- 13 -	Input receptacle for electronic key	GREEN
- 14 -	Engine Immobilization	BLACK marked "H"
- 15 -	Engine Immobilization	BLACK marked "H"
- 16 -	Turn indicators output	ORANGE
- 17 -	Turn indicators output	ORANGE
- 18 -	Turn indicators output common	WHITE-RED
- 19 -	-----	-----
- 20 -	-----	-----
- 21 -	-----	-----
- 22 -	-----	-----
- 23 -	-----	-----
- 24 -	-----	-----

**!** To activate the anti-hijack feature, the positive under key (BLACK wire marked "G") and the door push-button (GREEN-BROWN) MUST be connected. We recommend you ALWAYS make these connections.

## 6.0 - COMPLETE ELECTRIC DIAGRAM

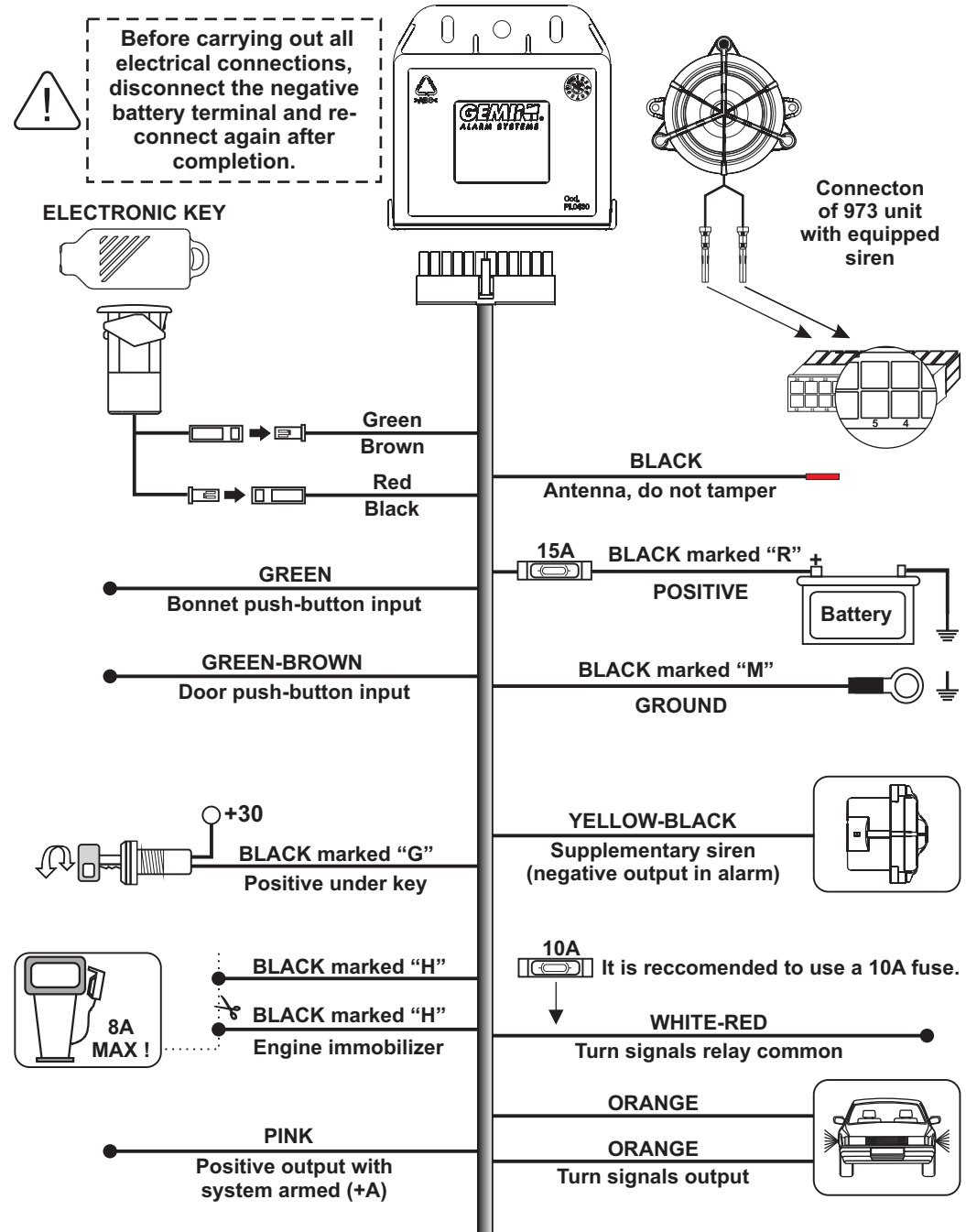

## 7.0 - SYSTEM PROGRAMMING

The table below applies to the system programmed in "standard configuration".  
Entering the programming procedure resets the functions to the default setting.

FUNCTION	STATUS
Arming/disarming acoustic signals	Enabled
Current absorption sensor	Disabled
Anti-hijack function	Enabled
Arming/disarming optic signals	Enabled

A lack of power during electrical system maintenance, will not affect programming.  
The procedure must be carried out completely; turning ignition key will only confirm the status of the selected function and move on to the next up to the end of the programming mode.  
The next paragraph illustrates a programming example.  
Programmable functions are briefly described below.

### 7.1 - ACOUSTIC SIGNALLING

This function activates the turn indicators during system arming (2) and disarming (3).

### 7.2 - CURRENT ABSORPTION SENSOR

This sensor triggers an alarm (when system is armed) whenever it detects a voltage change in the vehicle's electrical circuit.  
Before activating the current absorption sensor, consult the noise pollution regulations in force in your Country.

### 7.3 - ANTI-HIJACKING

This feature activates the system's anti-hijack procedure (see par. 3.0 for complete procedure).

### 7.4 - OPTICAL SIGNALLING



The alarm signals given by the flashing of the turn indicators should be deactivated if the vehicle already gives visual signals when locking/unlocking.

This function activates visual signals during system arming (2) and disarming (3).

## 8.0 - SYSTEM PROGRAMMING EXAMPLE

To better understand the programming procedure, here below is an example of the procedure to follow to modify the programmable functions.  
As mentioned before, ignition turn-on confirms function status, while the electronic key modifies it.  
Moreover, every time ignition key is turned or the electronic key is inserted in its receptacle, a high or low pitched signal is heard.

With alarm system disarmed, turn ignition key "ON".



The LED will flash for about one second.

During this period insert the electronic key into its receptacle.

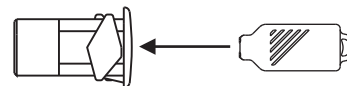

To indicate that the programming procedure has started, the LED will turn on steady and a high-pitched acoustic signal followed by a low-pitched acoustic signal will sound.

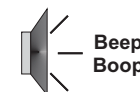

To keep the setting as it is, turn ignition "OFF" and then back "ON".  
A low-pitched audio signal will confirm the operation.

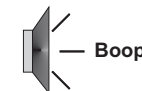

To change the operating state, put the electronic key once in its receptacle.  
A high-pitched audio signal will confirm the operation.

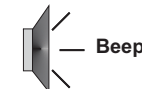

In both cases, the system will move on to the next function.

Repeat these same operations for the other functions.

Once the last function is programmed, turn ignition key "OFF" and "ON" twice.  
There will be a high-pitched signal, the LED will turn off and you will hear two low-pitched signals followed by one high-pitched signal.

These last two acoustic signals indicate the end of the programming procedure.

## 9.0 - ADDING NEW DEVICES



To carry out this operation successfully, you must first make the required electrical connections (door switch, bonnet switch and positive under key).

The system can record a maximum of 11 devices, either electronic keys or TAG CARDS. To activate the procedure follow the indications reported below.

- With the alarm system disarmed, open and keep opened the bonnet and the driver door.



The following operations must be carried out within four seconds otherwise the procedure is invalidated.

- Turn ignition key over 4 times: "ON-OFF"- "ON-OFF"- "ON-OFF"- "ON".
- At the fourth rotation, keep ignition key "ON".
- The siren will chirp twice and the turn indicators will flash twice to indicate the learning procedure of new devices has started.



Do not close the bonnet otherwise the devices already saved will be deleted as described in the next paragraph.

- The system is now ready to receive the device codes.
- Depending on the device to be recorded, either insert the electronic key into its receptacle or let the system pick up the TAG signal.
- To indicate the new device is learned, the siren chirps once and the status LED blinks once.
- Repeat the above steps to record other devices.
- Turn ignition key to "OFF" and close bonnet and door.
- When the procedure is completed, the siren chirps once.



Storing memory is for 11 devices. If you store an extra one it will automatically delete the first device recorded in the system memory.

## 10.0 - DELETING PROGRAMMED DEVICES



To carry out this operation successfully, you must first make the required electrical connections (door switch, bonnet switch and positive under key).

The system has a delete mode to remove a programmed electronic key or TAG CARD. To activate the procedure follow the indications reported below.

- With the alarm system disarmed, open and keep opened the bonnet and the driver door.



The following operations must be carried out within four seconds otherwise the procedure is invalidated.

- Turn ignition key over 4 times: "ON-OFF"- "ON-OFF"- "ON-OFF"- "ON".
- At the fourth rotation, keep ignition key "ON".
- The siren will chirp twice and the turn indicators will flash twice to indicate that the delete procedure has been initiated.
- Close the bonnet; the LED turns on steady.
- Keep the bonnet closed for at least 8 seconds until all the devices are cancelled.



The devices will not be deleted if the bonnet is opened before 8 seconds.

- When this procedure is completed, the LED turns off, the siren chirps once and the turn indicators flash once.
- Turn ignition key to "OFF".

## 11.0 - ULTRASONIC VOLUMETRIC PROTECTION

### 11.1 - CONNECTION AND POSITIONING

Insert the WHITE connector into the port marked "W" and the RED connector into the port marked "R" (see figure below).

Install the sensor transducers at the top of each windscreen pillar, away from the air vents and orient them towards the center of the rear window.

### 11.2 - SENSOR ADJUSTMENT

To check sensitivity level proceed as follows:

- With the alarm system disarmed, roll down the front window about 20 cm.
- Adjust trimmer at a medium setting.
- Close all doors, bonnet and boot and arm the system.
- During the system inhibit arming time introduce an object in the cabin through the window and move it around; the status LED will turn off to indicate object detection.
- If sensitivity is too high or too low, readjust the trimmer and repeat the above procedure.

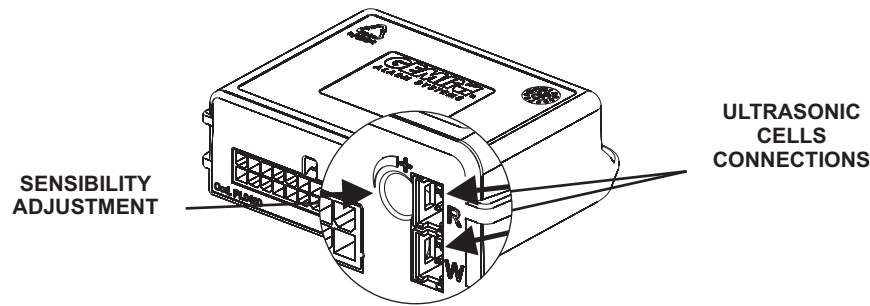

## 12.0 - WASTE ELECTRICAL AND ELECTRONIC EQUIPMENT (WEEE) DIRECTIVE

In the European Union, this label indicated that this product should not be disposed of with household waste. It should be deposited at an appropriate facility to enable recovery and recycling (directive 2002/95/CE, 2002/96/CE and 2003/108/CE).

For information on how to recycle this product responsibly in your Country, please visit the web-site: [Www.eur-lex.europa.eu](http://Www.eur-lex.europa.eu)



## 13.0 - TAG CARD ACTIVATION AND BATTERY REPLACEMENT

To activate the TAG CARD simply press the button and keep it pressed for at least 4 seconds. The LED turns on steady when the TAG is activated and it will flash each time the TAG transmits. If not moved for 10 min., the TAG will automatically go into standby to save battery life; to 'wake it up' for another transmission cycle (10 min.), move it or press the button. Another short button press will send a radio signal to the alarm system. To turn the TAG off, press the button and keep it pressed for at least 8 seconds. The LED stays on steady and after 8 seconds it will flash briefly to indicate the TAG is switched off. To replace battery proceed as follows:

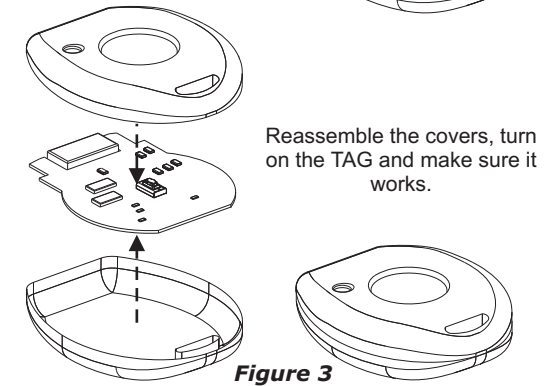
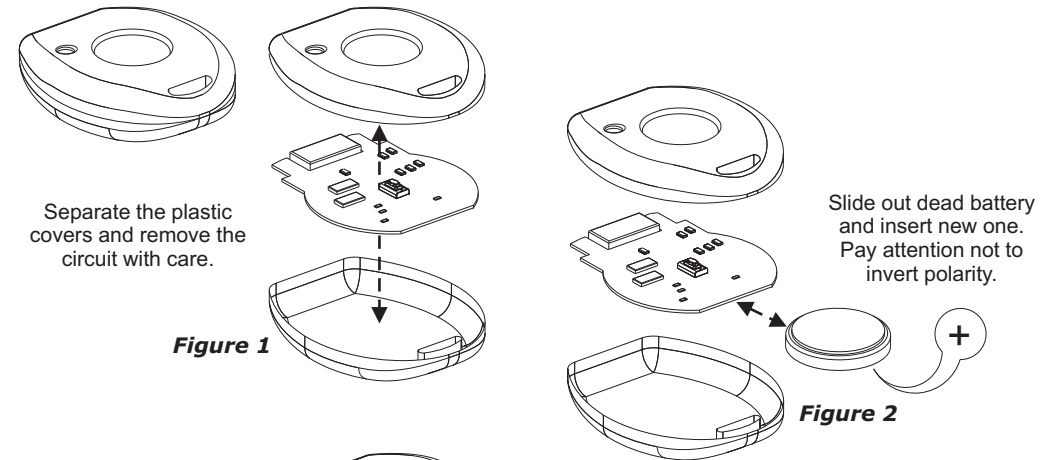

Use ONLY CR2032 type battery; do not discard used batteries in trash but safely dispose in appropriate containers.

#### 14.0 - WARRANTY CONDITIONS

This product is guaranteed to be free from defects in workmanship for a period of 24 months from the date of installation reported on this warranty, in compliance with the 1999/44/CE Warranty Directive (L.D. N° 24 of the 02/02/2002).

Please fill-in entirely the guarantee certificate included in this booklet and DO NOT REMOVE the guarantee label from the device.

The warranty will become void if labels are missing or torn, if the installation certificate is not fully compiled or if the enclosed sale document is missing.

The warranty is valid exclusively at Authorized Gemini Centers.

The manufacturer declines any responsibility for eventual malfunctions of the device or any damage to the vehicle electrical system due to improper installation, use or tampering.

This alarm is solely intended to be a theft-deterrent device.

#### 15.0 - TECHNICAL DATA

Operating power	12 Vdc
Current absorption @ 12Vdc with system armed and LED flashing	Less than 15 mA
Operating temperature range	From -30°C to +70°C
Turn signals relay contact capability	8 A to 20°C
Engine immobilisation relay contact capability	8 A to 20°C
Alarm cycle	30 sec.
Horn output current capacity	5 A